

**SECTION A-A**

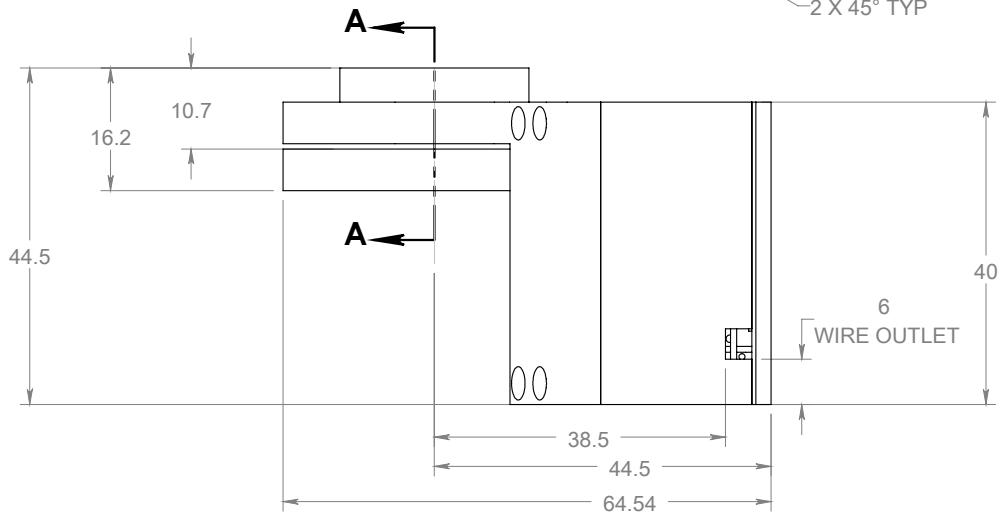

| TABLE 1 |                     |                  |
|---------|---------------------|------------------|
| SIZE    | THREAD SIZE (DIM A) | DIAMETER (DIM B) |
| OBJ - 1 | M19x0.75            | 14.0             |
| OBJ - 2 | M25x0.75            | 22.0             |
| OBJ - 3 | M26x0.75            | 23.0             |
| OBJ - 4 | M27x0.75            | 24.0             |
| OBJ - 5 | M28x0.75            | 25.0             |
| OBJ - 6 | M32x0.75            | 29.0             |
| OBJ - 7 | M26x1/36"           | 22.0             |
| OBJ - 8 | W0.8x1/36"          | 14.0             |
| OBJ - 9 | W26x 1/36"          | 22.0             |

LINEAR TOLERANCES ARE:  
 .XX ± .02  
 .X ± .08  
 . ± .15  
 ANGULAR TOLERANCES ARE:  
 ± .5°

UNLESS OTHERWISE NOTED, ALL UNITS ARE IN MILLIMETERS

THIRD ANGLE PROJECTION

nPoint, Inc.  
 3030 Laura Ln. Ste. 100  
 Middleton, WI 53562  
 Phone: (608) 824-1770  
 Fax: (608) 824-1774  
 www.npoint.com

| APPROVALS  |      | DATE         |
|--|------|--------------|
| DRAWN: BCR                                       |      | 12-MAR-13    |
| DESCRIPTION                                      |      |              |
| nPFocus1000<br>1-AXIS SCANNER<br>1000um Z TRAVEL |      |              |
| NUMBER   | REV. | SHEET 1 OF 1 |
| 3715250  | A    |              |