

CLAMP CONFIGURATION

SECTION D-D  
SCALE 1 : 1

TABLE 1: DIM B

TABLE 1: DIM A

TABLE 1: DIM A

TABLE 1

SIZE	THREAD SIZE (DIM A)	DIAMETER (DIM B)
OBJ - 1	M19 X 0.75	14.0
OBJ - 2	M25 X 0.75	22.0
OBJ - 3	M26 X 0.75	23.0
OBJ - 4	M27 X 0.75	24.0
OBJ - 5	M28 X 0.75	25.0
OBJ - 6	M32 X 0.75	29.0
OBJ - 7	M26 X 1/36"	22.0
OBJ - 8	W0.8 X 1/36"	14.0
OBJ - 9	W26 X 1/36"	22.0

LINEAR TOLERANCES ARE:  
 .XX ± .02  
 .X ± .08  
 . ± .15  
 ANGULAR TOLERANCES ARE:  
 ± .5°

UNLESS OTHERWISE NOTED, ALL UNITS ARE IN MILLIMETERS

THIRD ANGLE PROJECTION

nPoint, Inc.  
 3030 Laura Ln. Ste. 100  
 Middleton, WI 53562  
 Phone: (608) 824-1770  
 Fax: (608) 824-1774  
 www.npoint.com

APPROVALS		DATE
DRAWN: NJE		05-01-2018
DESCRIPTION		
nPFocus400 C/SG 1-AXIS SCANNER 400um Z TRAVEL		
NUMBER	REV.	
3715475/485	B	SHEET 1 OF 2

8 7 6 5 4 3 2 1

D

C

B

A

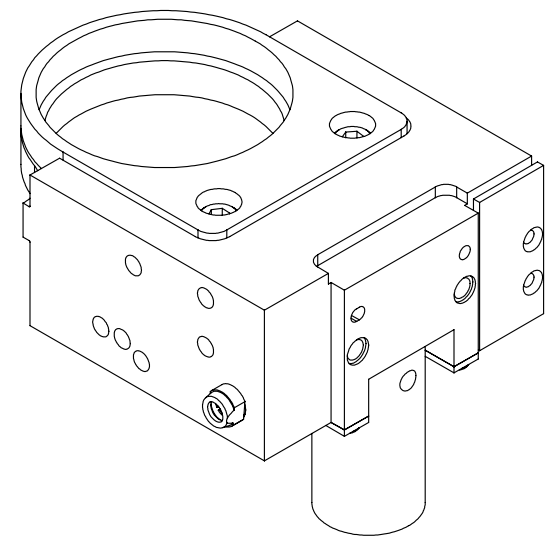
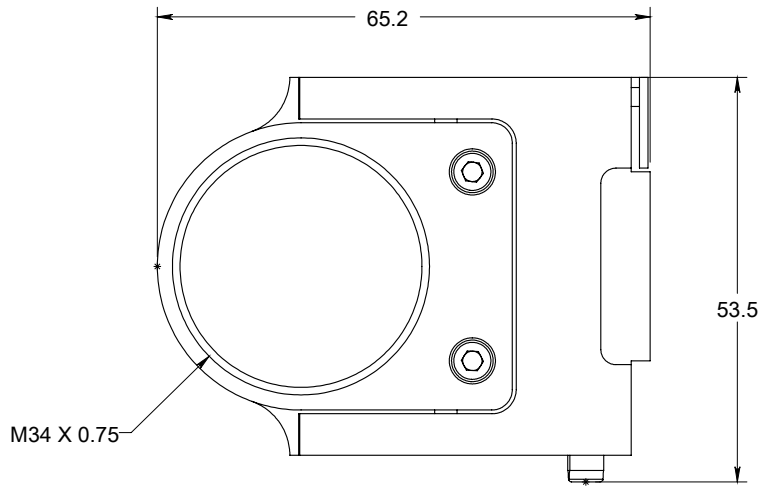

**SECTION B-B  
SCALE 1 : 1**

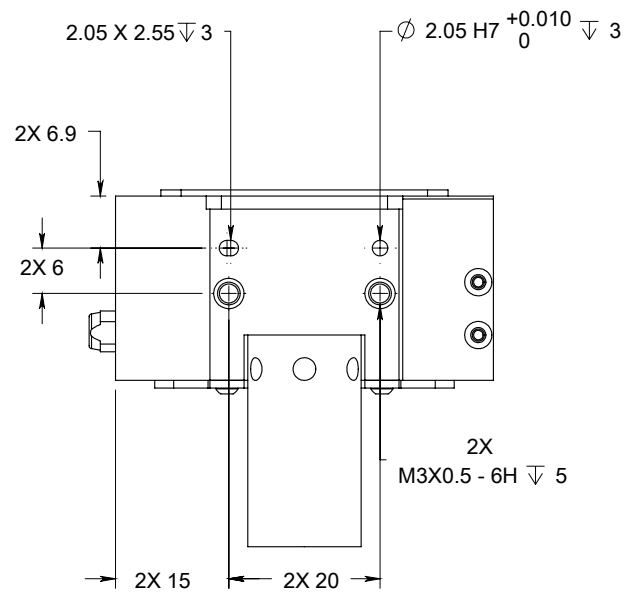
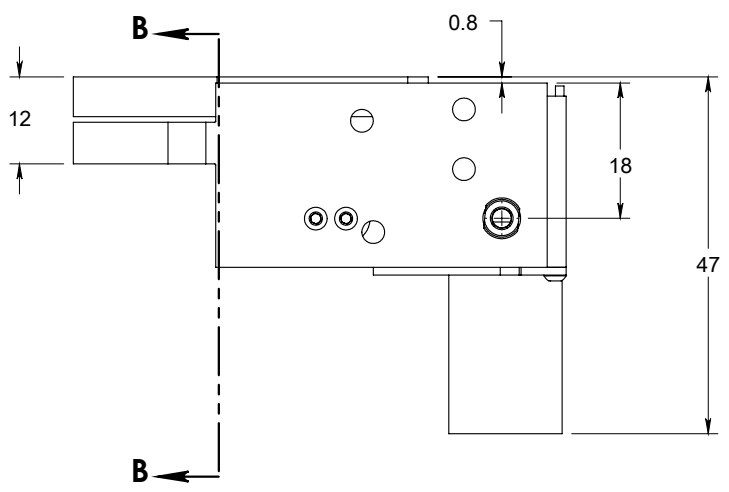
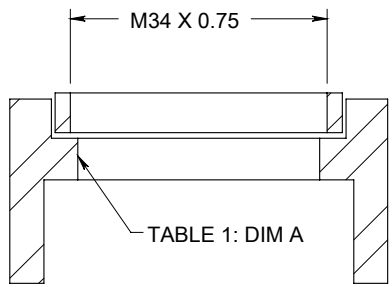
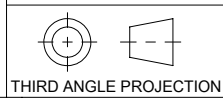

TABLE 1

SIZE	THREAD SIZE (DIM A)
OBJ - 1	M19 X 0.75
OBJ - 2	M25 X 0.75
OBJ - 3	M26 X 0.75
OBJ - 4	M27 X 0.75
OBJ - 5	M28 X 0.75
OBJ - 6	M32 X 0.75
OBJ - 7	M26 X 1/36"
OBJ - 8	W0.8 X 1/36"
OBJ - 9	W26 X 1/36"

UNLESS OTHERWISE NOTED, ALL UNITS ARE IN MILLIMETERS



nPoint, Inc.  
3030 Laura Ln. Ste. 100  
Middleton, WI 53562  
Phone: (608) 824-1770  
Fax: (608) 824-1774  
www.npoint.com

APPROVALS		DATE
DRAWN: NJE		05-01-2018
DESCRIPTION nPFocus400 C/SG 1-AXIS SCANNER 400um Z TRAVEL		
NUMBER 3715475/485	REV. B	SHEET 2 OF 2

8 7 6 5 4 3 2 1