

8 7 6 5 4 3 2 1

REVISIONS						
ZONE	REV.	DESCRIPTION	REVISED	DATE	APPROVED	DATE
	1					

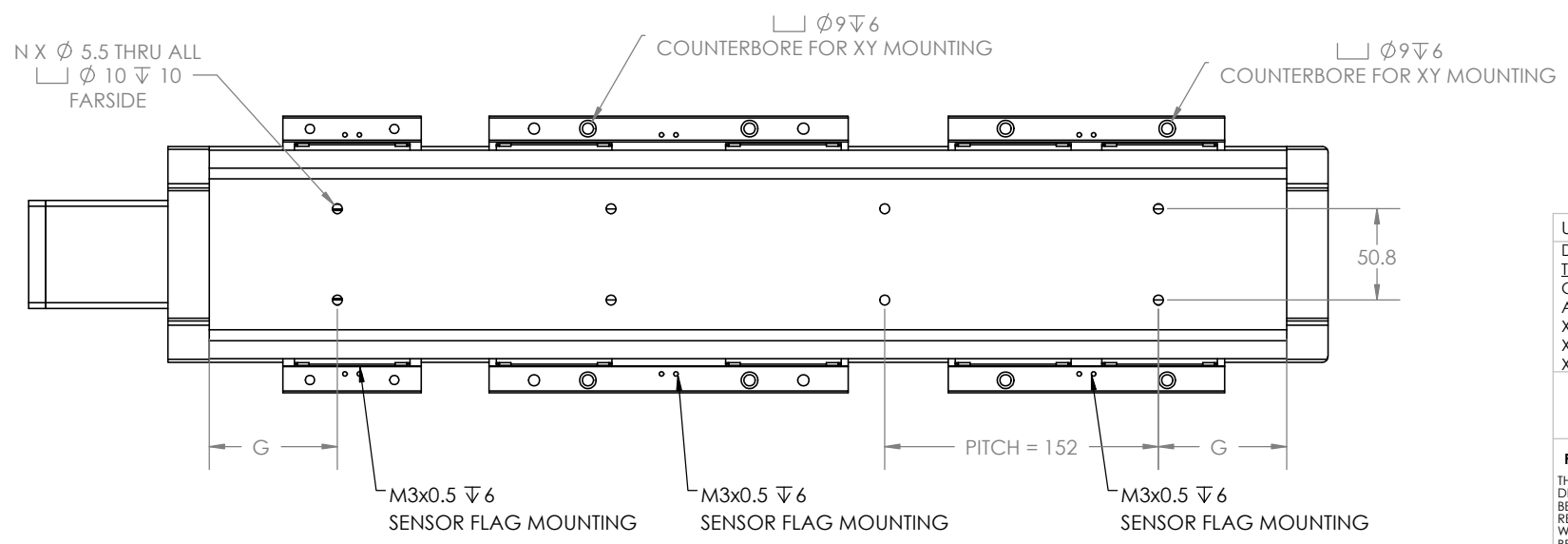
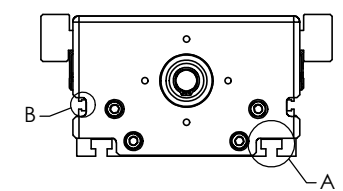
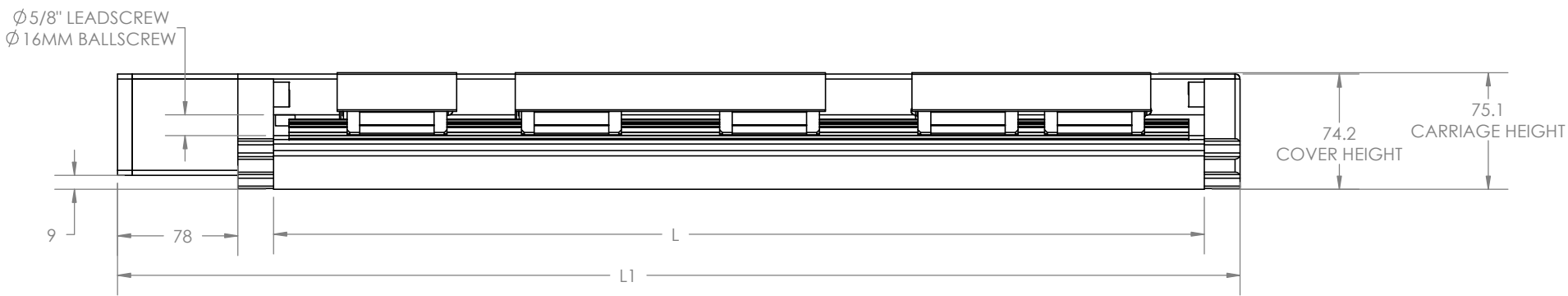
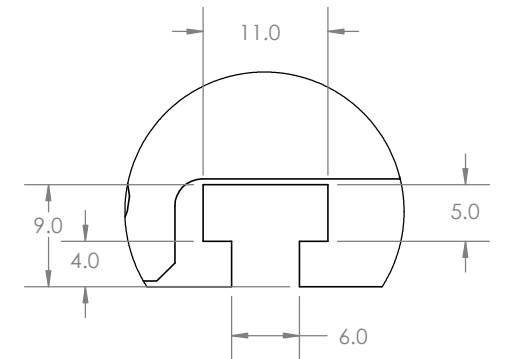
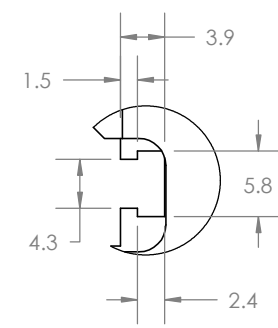
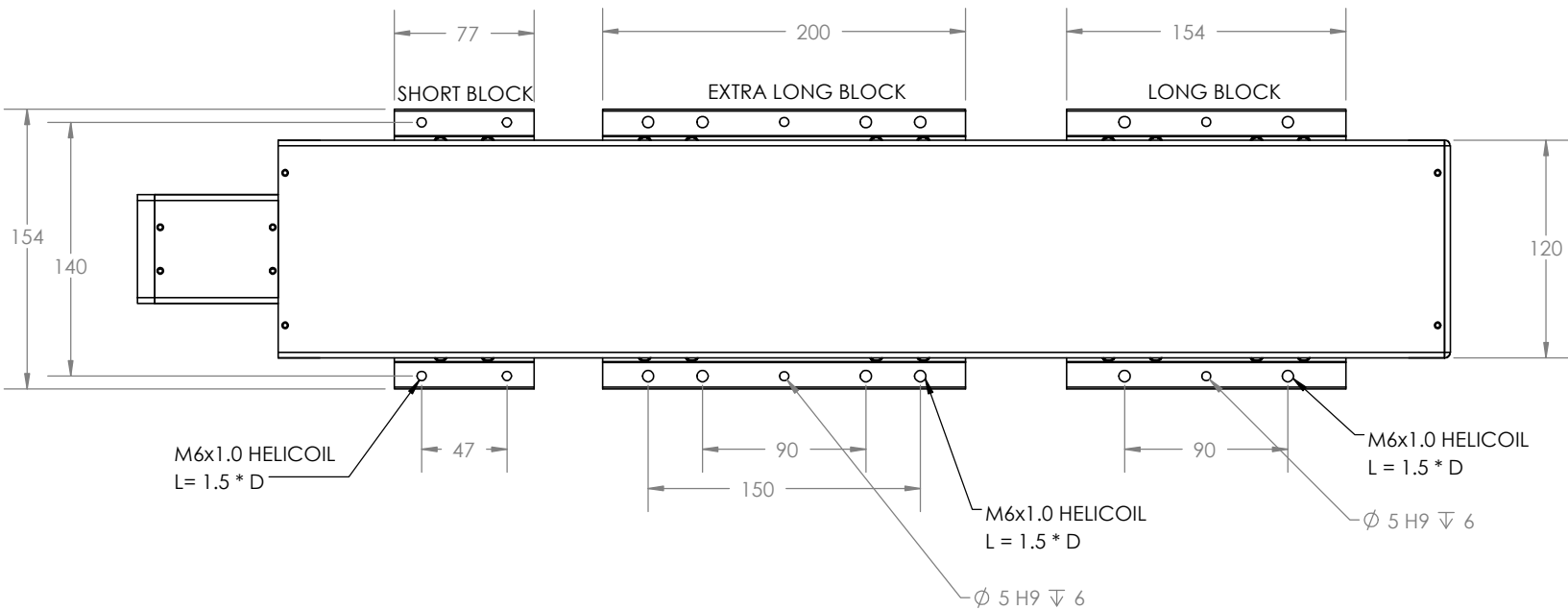

UNLESS OTHERWISE SPECIFIED:
 DIMENSIONS ARE IN MILLIMETER
 TOLERANCES:
 CLEARANCE HOLE: X.XX -0/+0.5
 ANGULAR: MACH ±.5° BEND ±.5°
 X.X ± 0.76
 X.XX ± 0.25
 X.XXX ± 0.13

1.6 THIRD ANGLE PROJECTION

PROPRIETARY AND CONFIDENTIAL
 THE INFORMATION CONTAINED IN THIS DRAWING IS THE SOLE PROPERTY OF BEARING ENGINEERS, INC. ANY REPRODUCTION IN PART OR AS A WHOLE WITHOUT THE WRITTEN PERMISSION OF BEARING ENGINEERS, INC. IS PROHIBITED.

	NAME	DATE
DRAWN	-	-
CHECKED	-	-
ENG APPR.	-	-
MFG APPR.	-	-
Q.A.	-	-
COMMENTS:		

npoint A division of **MOTION SOLUTIONS**

TITLE: **HDS75 CATALOG**

SIZE	DWG. NO.	REV
B	HDS CATALOG	

SCALE: 1:10 SHEET 1 OF 6

8 7 6 5 4 3 2 1

8 7 6 5 4 3 2 1

D

D

FIXED-FIXED SUPPORT
SCREW IS TENSIONED
SECOND SET OF BEARINGS IN TANDEM INCREASES THRUST LOAD CAPACITY

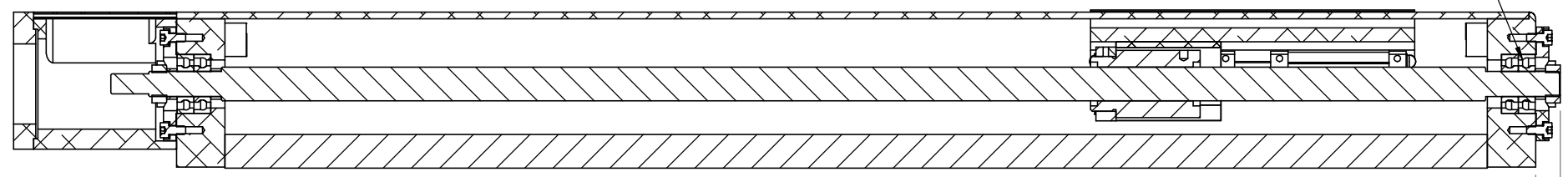

11.7 ADDITIONAL LENGTH

HIGH THRUST

C

C

FIXED-SIMPLE SUPPORT
SCREW IS MORE EASILY ALIGNED

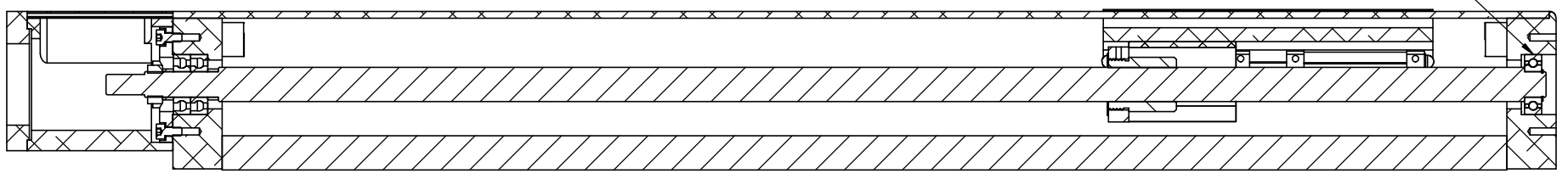

STANDARD

B

B

A

A



SIZE	DWG. NO.	REV
B	HDS75 CATALOG	
SCALE: 1:10		SHEET 2 OF 6

8 7 6 5 4 3 2 1

8 7 6 5 4 3 2 1

D

D

C

C

B



B

A

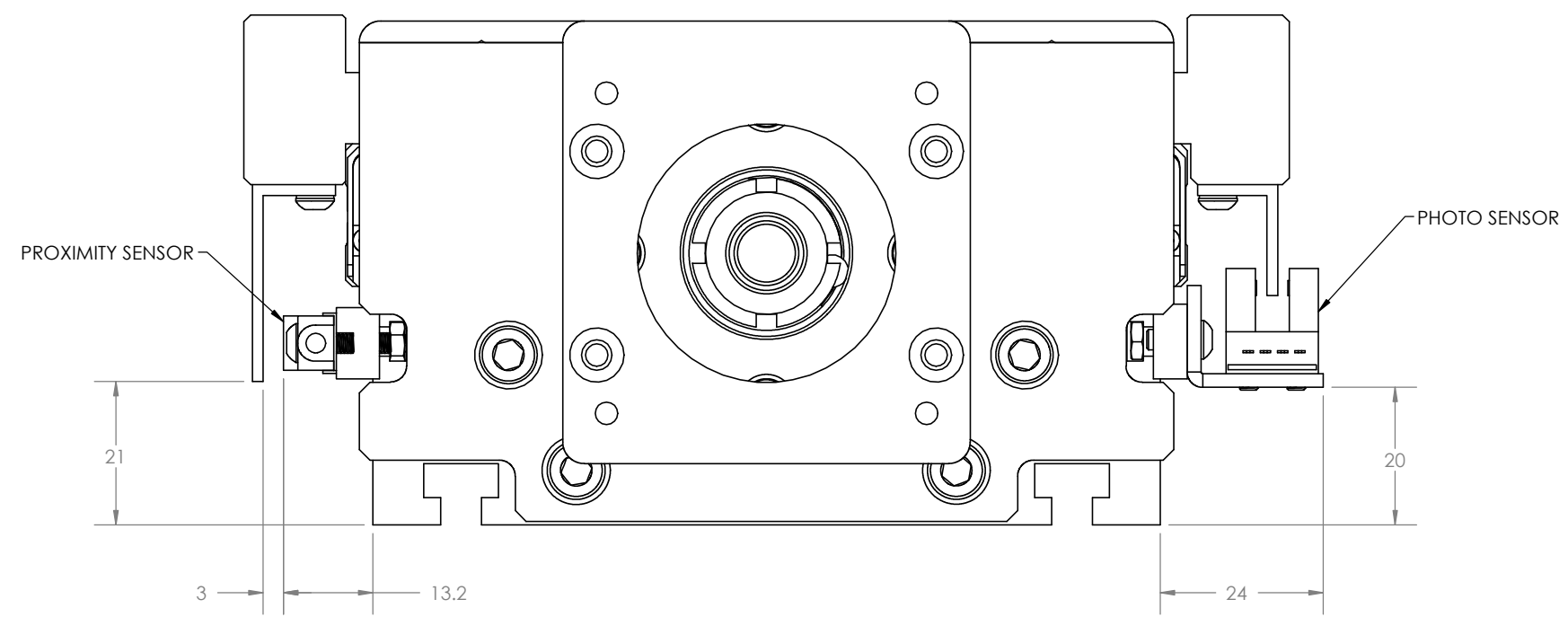
A



SENSORS

 npoint A division of		
SIZE	DWG. NO.	REV
B	HDS75 CATALOG	
SCALE: 1:10		SHEET 3 OF 6

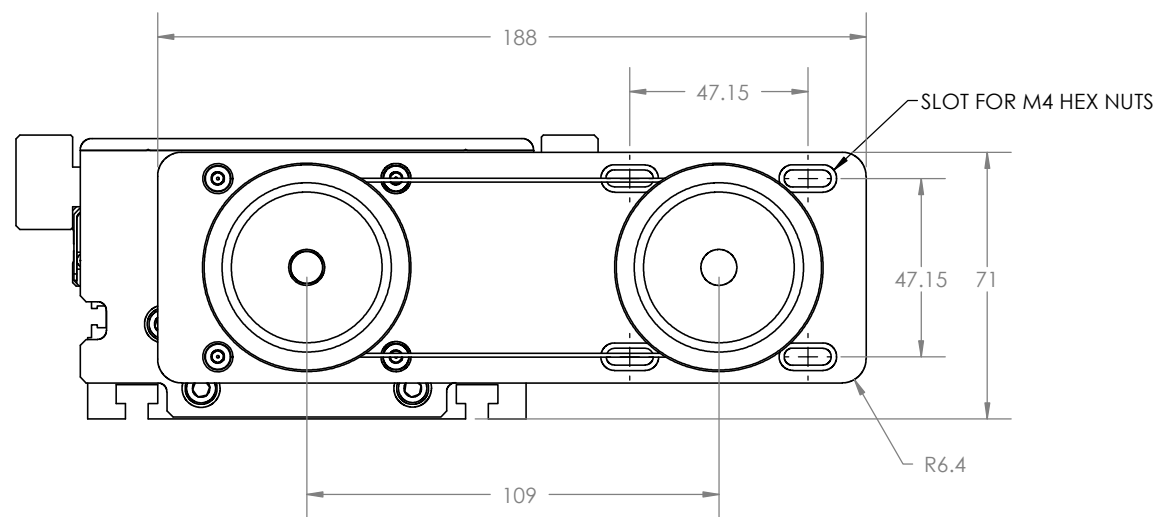
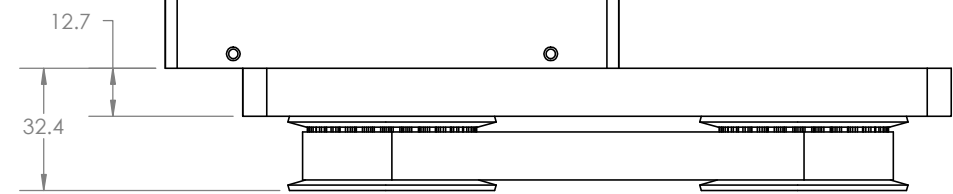

8 7 6 5 4 3 2 1

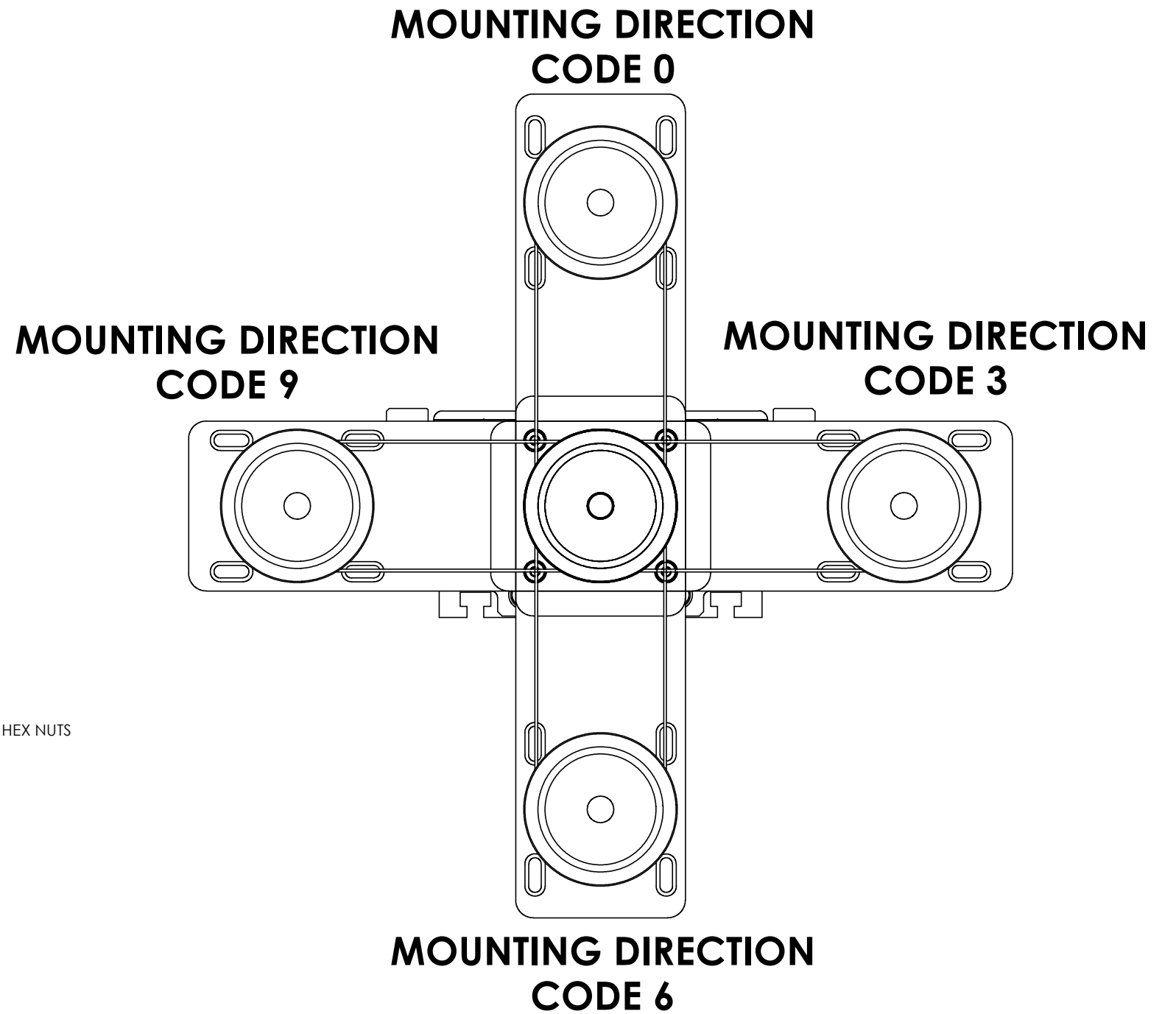

B3 NEMA 23 WRAP BRACKET

INCLUDED PULLEYS: 28-TEETH, XL
TIMING BELT: 1/2" POLYURETHANE WITH STEEL CORE, 78 TEETH, XL



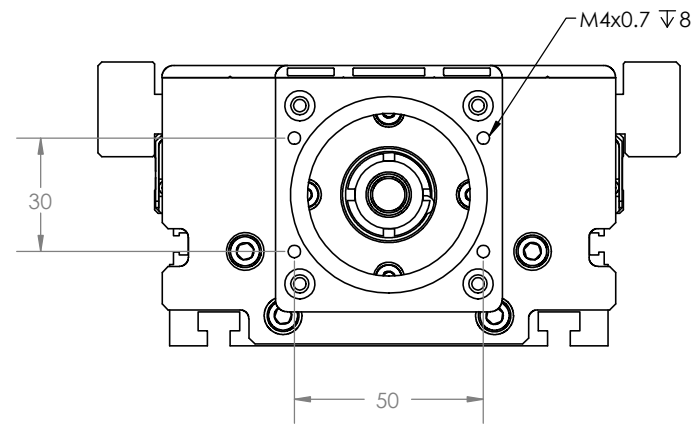
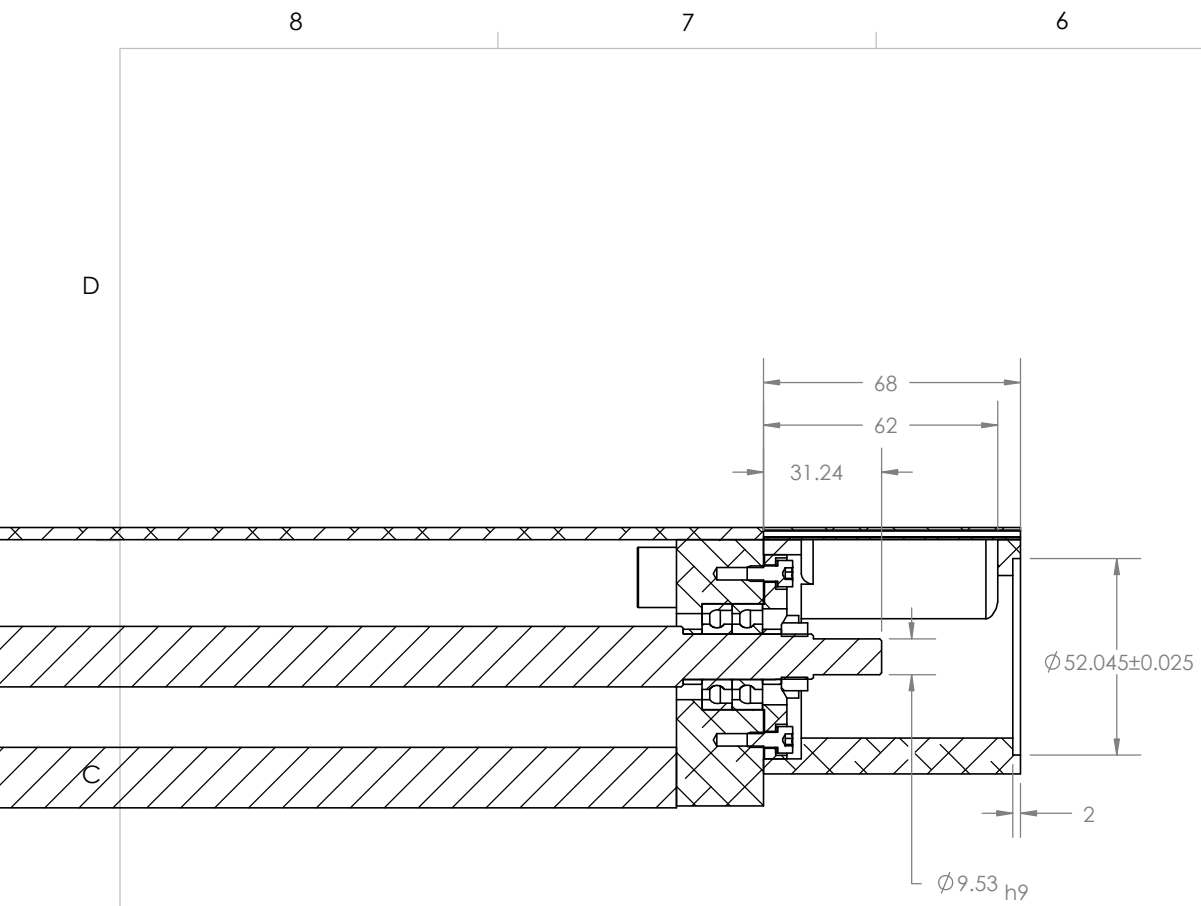

 A division of 		
SIZE	DWG. NO.	REV
B	HDS75 CATALOG	
SCALE: 1:10		SHEET 4 OF 6

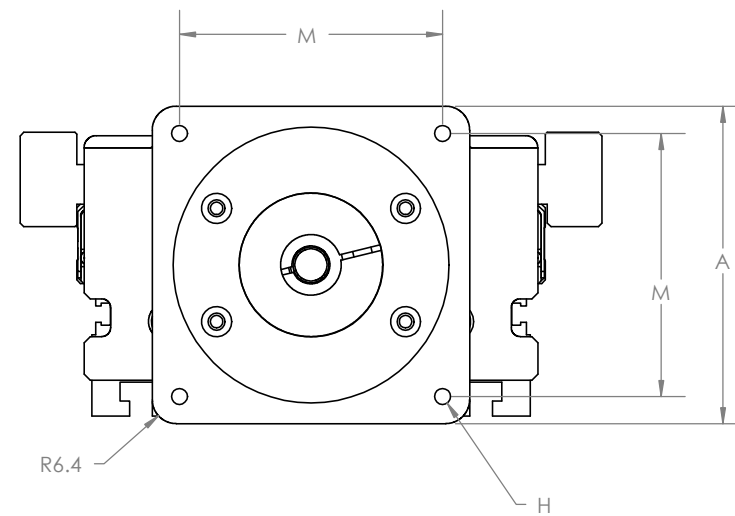
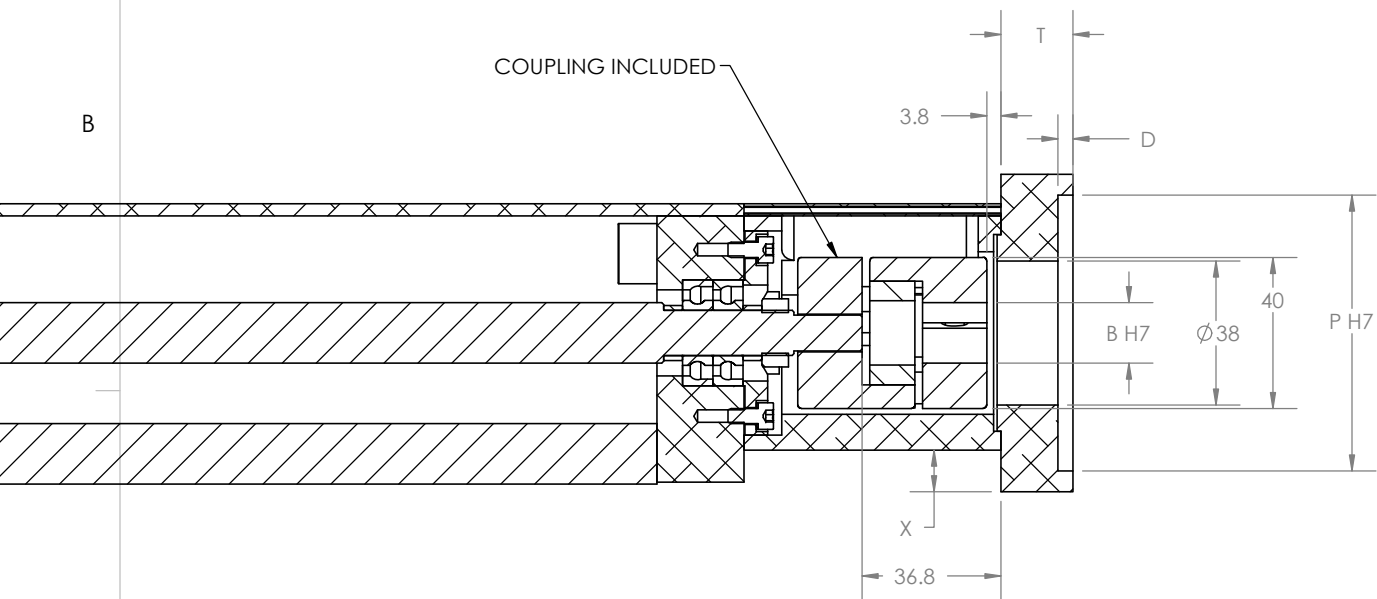

B0



HDS75 MOTOR FLANGES

 A division of 		
SIZE	DWG. NO.	REV
B	HDS75 CATALOG	
SCALE: 1:10		SHEET 5 OF 6

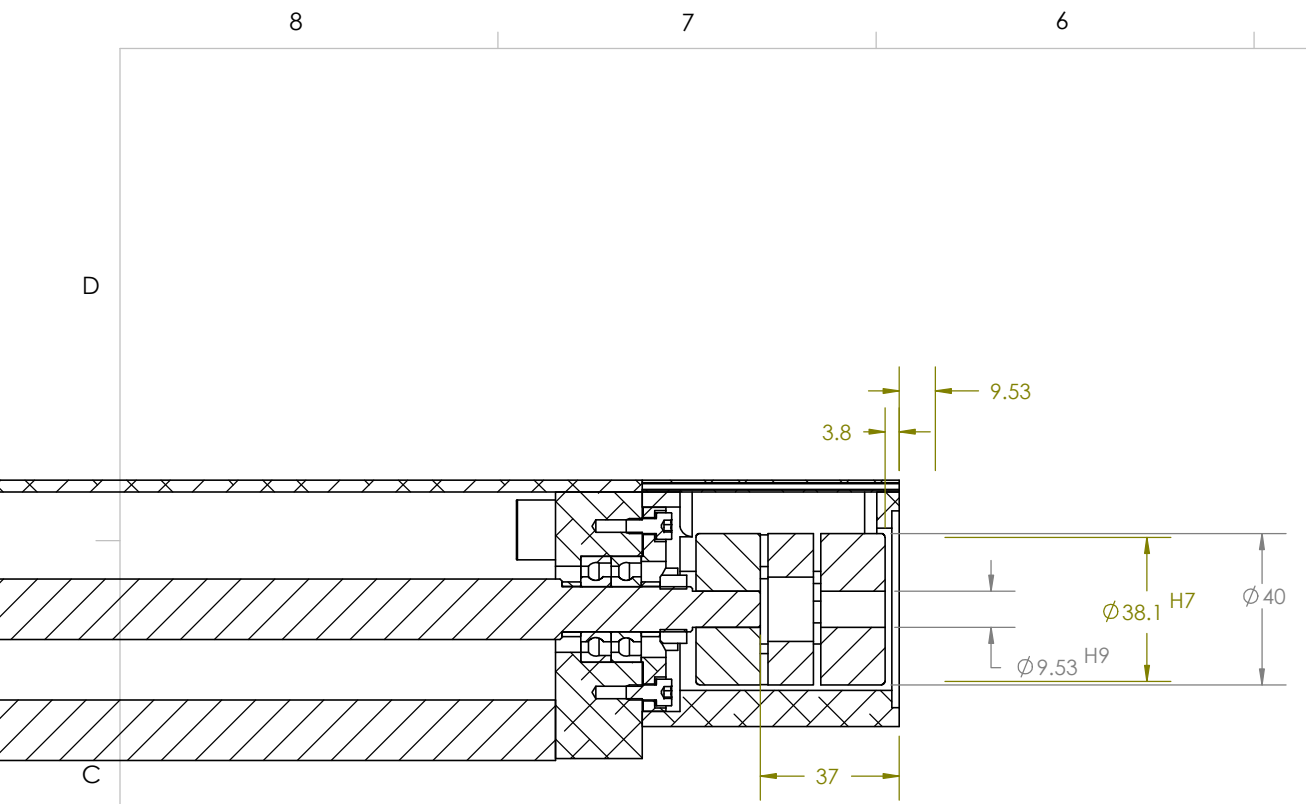

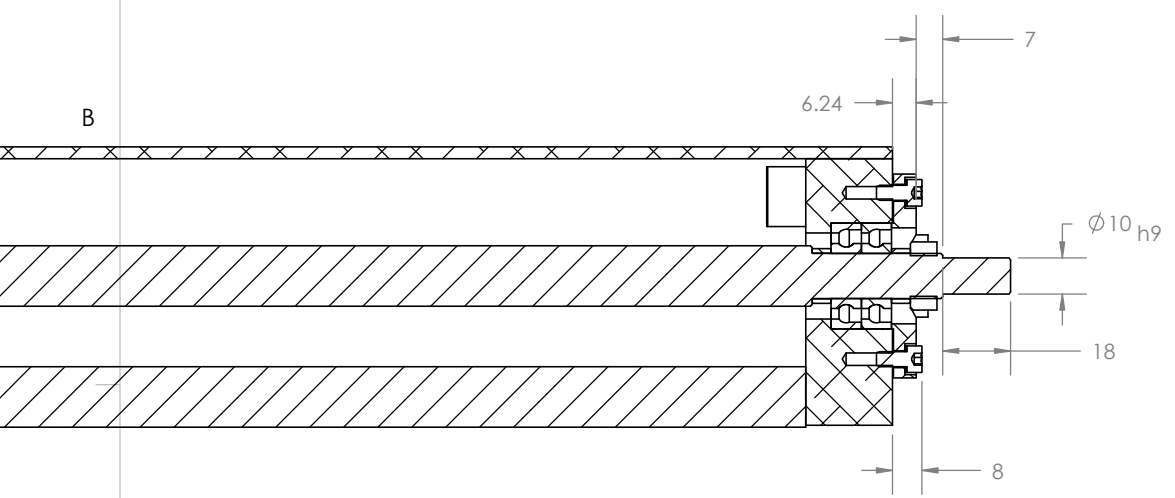
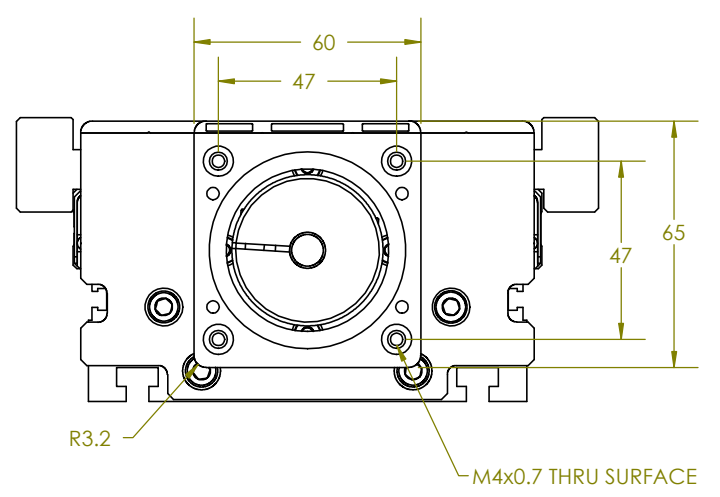

B2

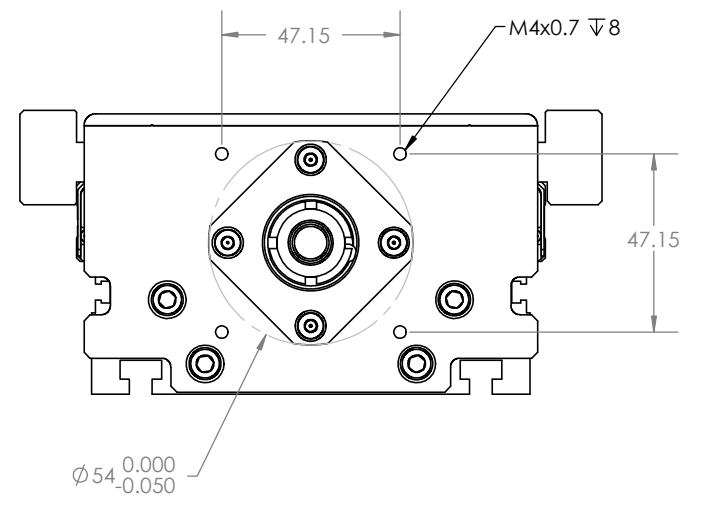

R0



 A division of 		
SIZE	DWG. NO.	REV
B	HDS75 CATALOG	
SCALE: 1:10	SHEET 6 OF 6	